



US006249316B1

(12) **United States Patent**
Anderson

(10) **Patent No.:** **US 6,249,316 B1**
(45) **Date of Patent:** ***Jun. 19, 2001**

(54) **METHOD AND SYSTEM FOR CREATING A TEMPORARY GROUP OF IMAGES ON A DIGITAL CAMERA**

(75) Inventor: **Eric C. Anderson**, San Jose, CA (US)

(73) Assignee: **FlashPoint Technology, Inc.**, San Jose, CA (US)

(*) Notice: This patent issued on a continued prosecution application filed under 37 CFR 1.53(d), and is subject to the twenty year patent term provisions of 35 U.S.C. 154(a)(2).

Subject to any disclaimer, the term of this patent is extended or adjusted under 35 U.S.C. 154(b) by 0 days.

(21) Appl. No.: **08/702,286**

(22) Filed: **Aug. 23, 1996**

(51) **Int. Cl.**⁷ **H04N 5/225**

(52) **U.S. Cl.** **348/333.05; 345/115**

(58) **Field of Search** 348/333, 232, 348/552, 333.05; 345/338, 351, 115; 396/373, 429

(56) **References Cited**

U.S. PATENT DOCUMENTS

4,827,347	*	5/1989	Bell	348/333.05
5,020,012		5/1991	Stockberger	.	
5,043,816	*	8/1991	Nakano et al.	348/333
5,237,648	*	8/1993	Mills et al.	395/133
5,414,811	*	5/1995	Parulski et al.	395/162
5,488,414	*	1/1996	Hirasawa et al.	348/207

5,633,678	*	5/1997	Parulski et al.	348/232
5,635,984	*	6/1997	Lee	348/333
5,675,358	*	10/1997	Bullock et al.	345/115
5,682,207	*	10/1997	Takeda et al.	348/568
5,706,049	*	1/1998	Moghadam et al.	348/333
5,740,267	*	4/1998	Erherer et al.	382/132
5,742,339	*	4/1998	Wakui	348/233
5,796,428	*	8/1998	Matsumoto	348/231
5,828,406		10/1998	Parulski	.	
5,862,218	*	1/1999	Steinberg	348/552
5,943,050	*	8/1999	Bullock et al.	348/333.05
5,966,122	*	10/1999	Itoh	348/232

* cited by examiner

Primary Examiner—Wendy R. Garber

(74) *Attorney, Agent, or Firm*—Sawyer Law Group LLP

(57) **ABSTRACT**

A method and system for grouping a series of images stored in a digital camera. The digital camera includes a view finder for displaying a plurality of the image cells, where each of the image cells corresponds to one of the stored images. The digital camera also includes a navigation control button for positioning a highlight area around one of the plurality of image cells, and one or more function keys. The method and system includes assigning a mark function to one of the function keys, such that in response to the user pressing the assigned mark function key, the image cell currently highlighted is marked to provide a marked image. In response to the user repeating the above step, a group of marked images is created. The method and system further includes assigning at least one group function to one of the function keys, such that in response to a user pressing the assigned group function key, the group of marked images is collectively manipulated by the user.

12 Claims, 11 Drawing Sheets

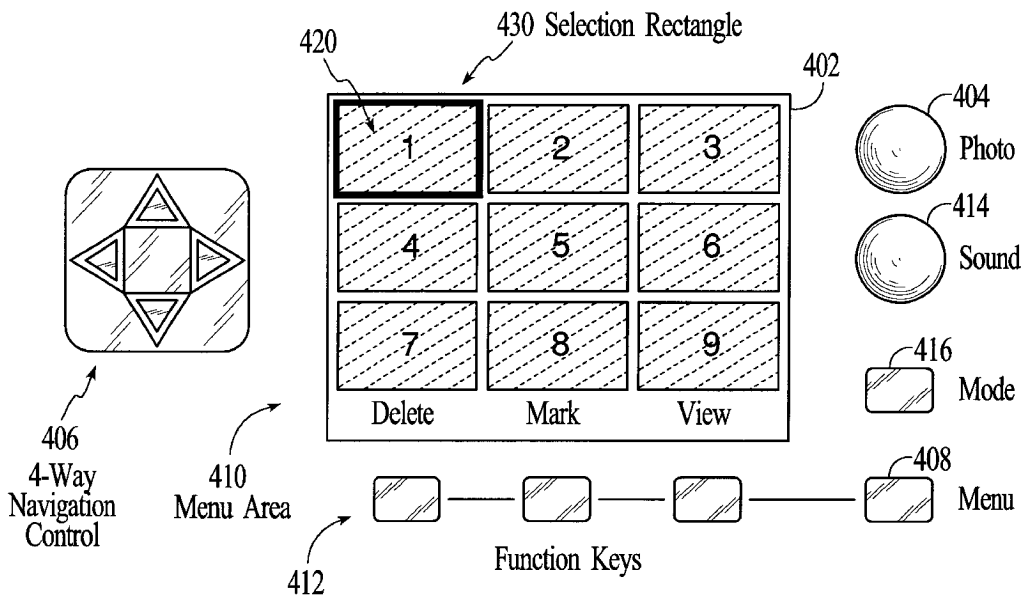

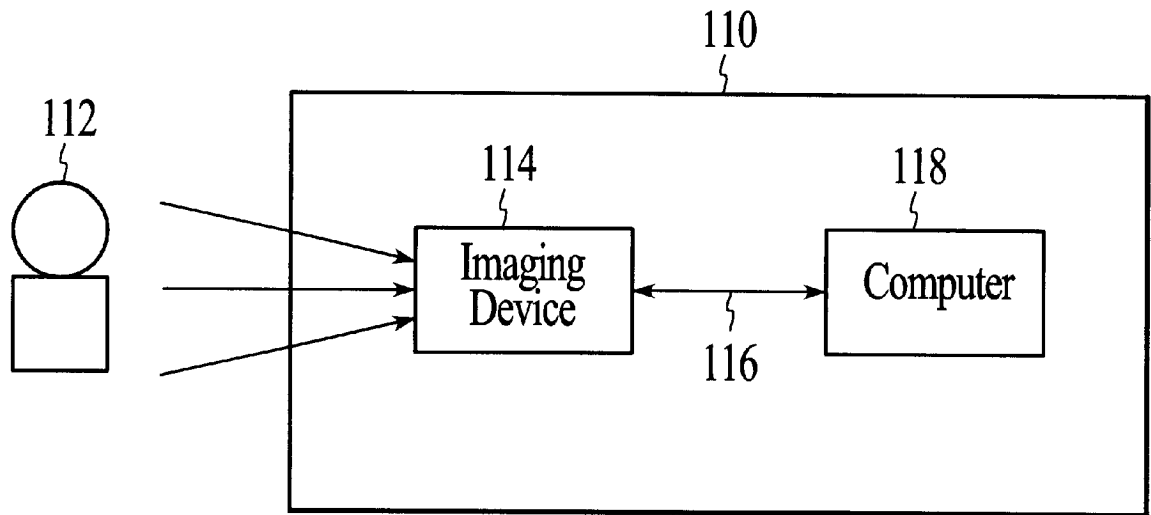

FIG. 1

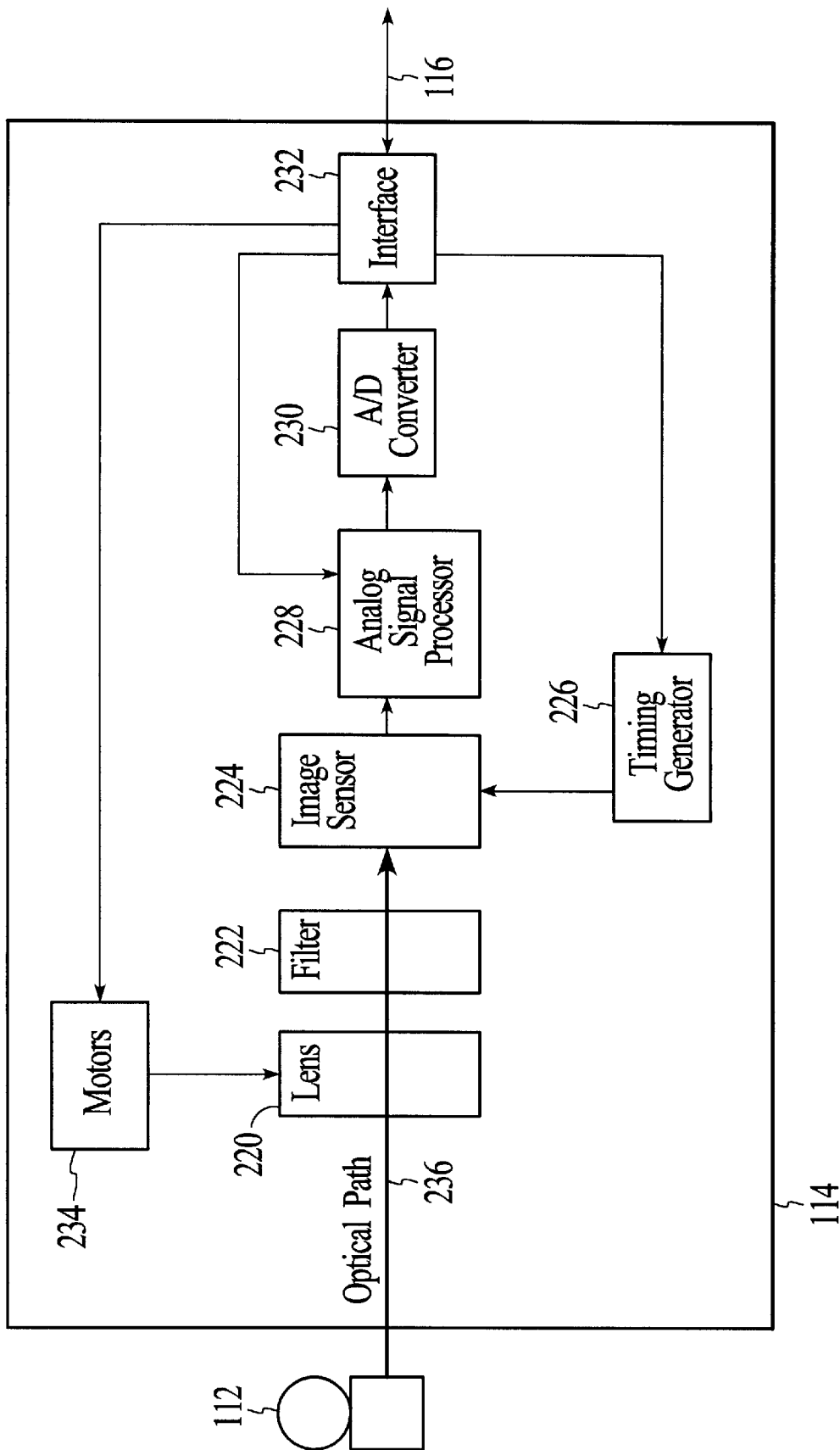

FIG. 2

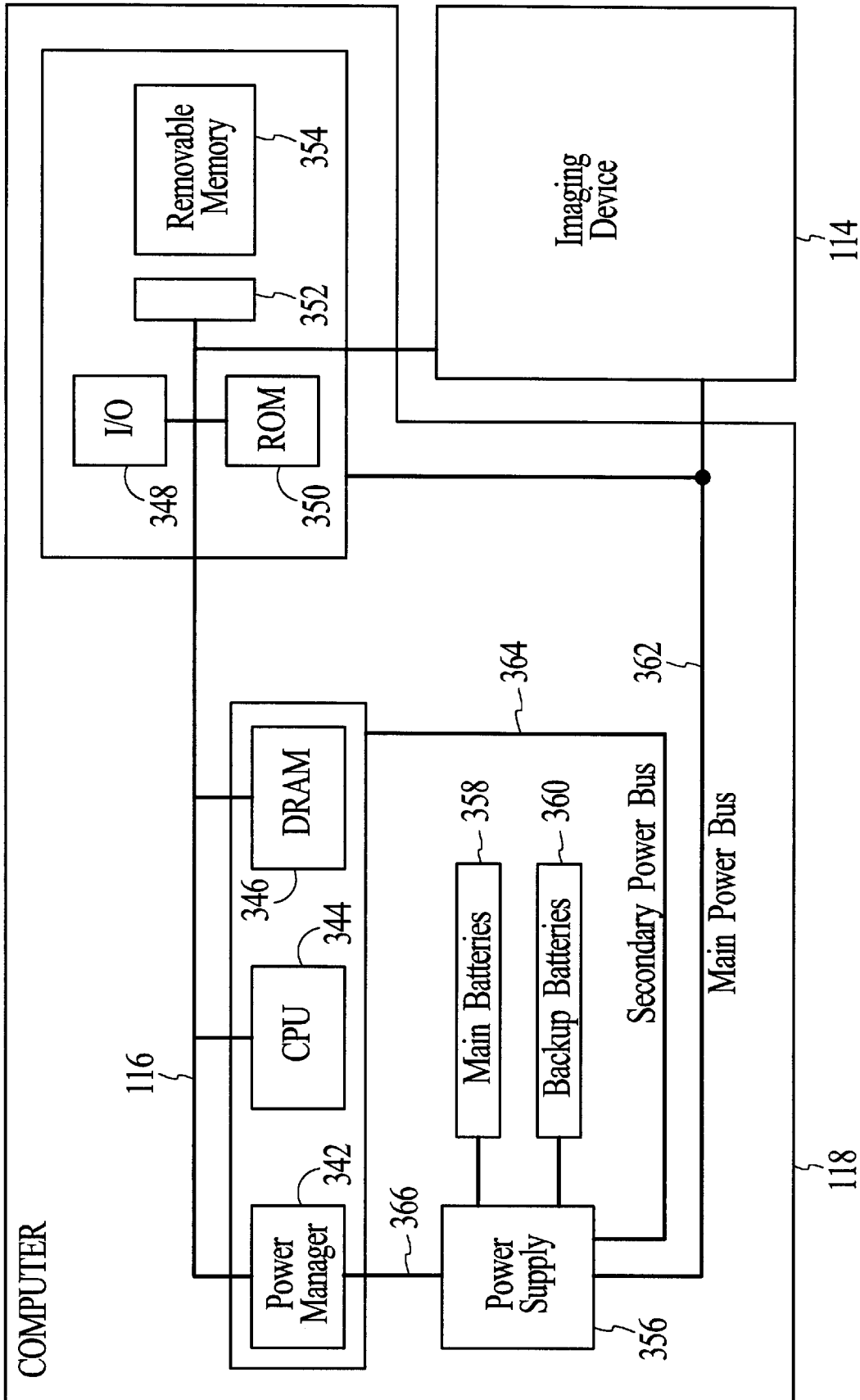

FIG. 3

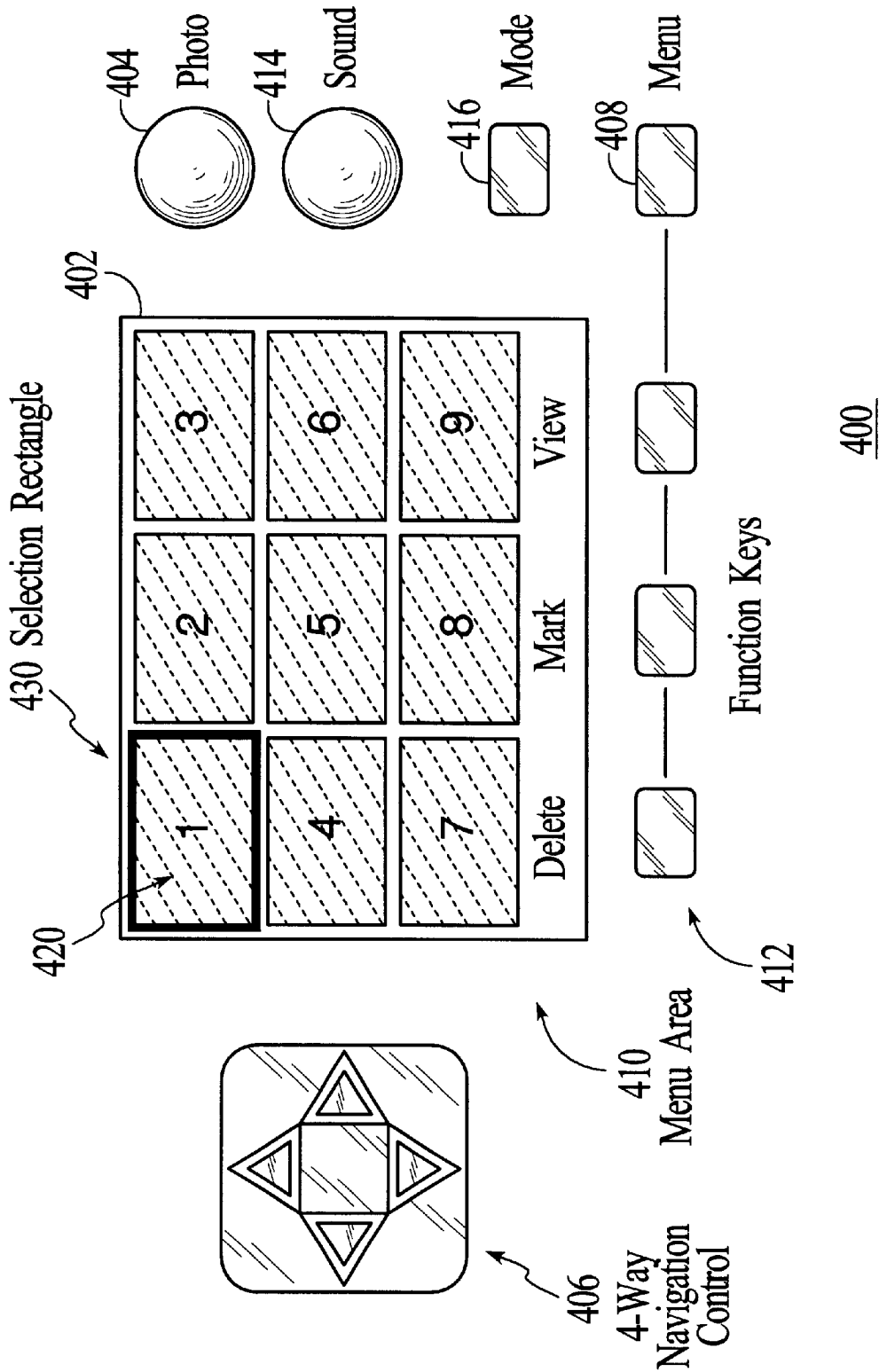

FIG. 4

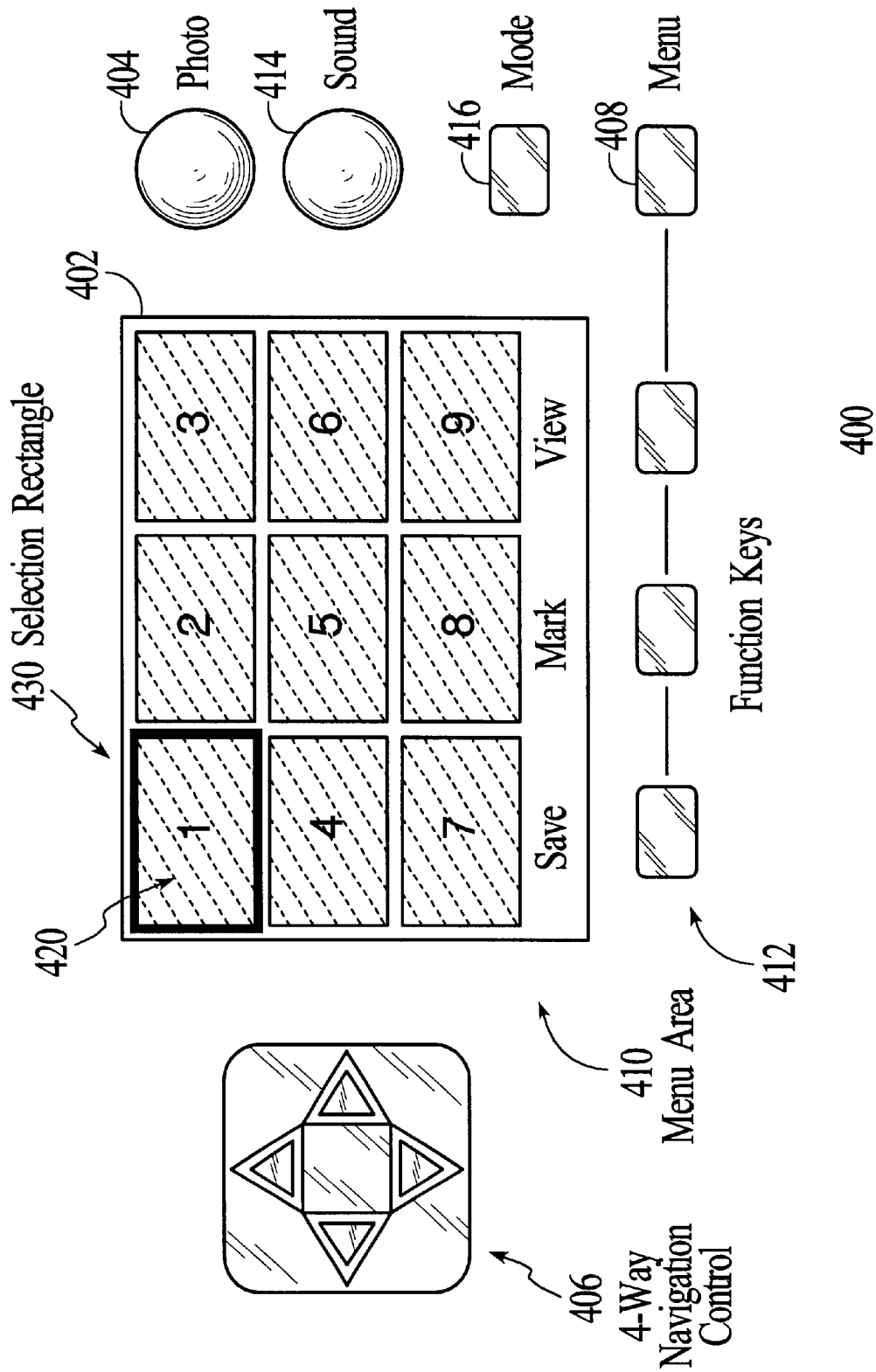

FIG. 5

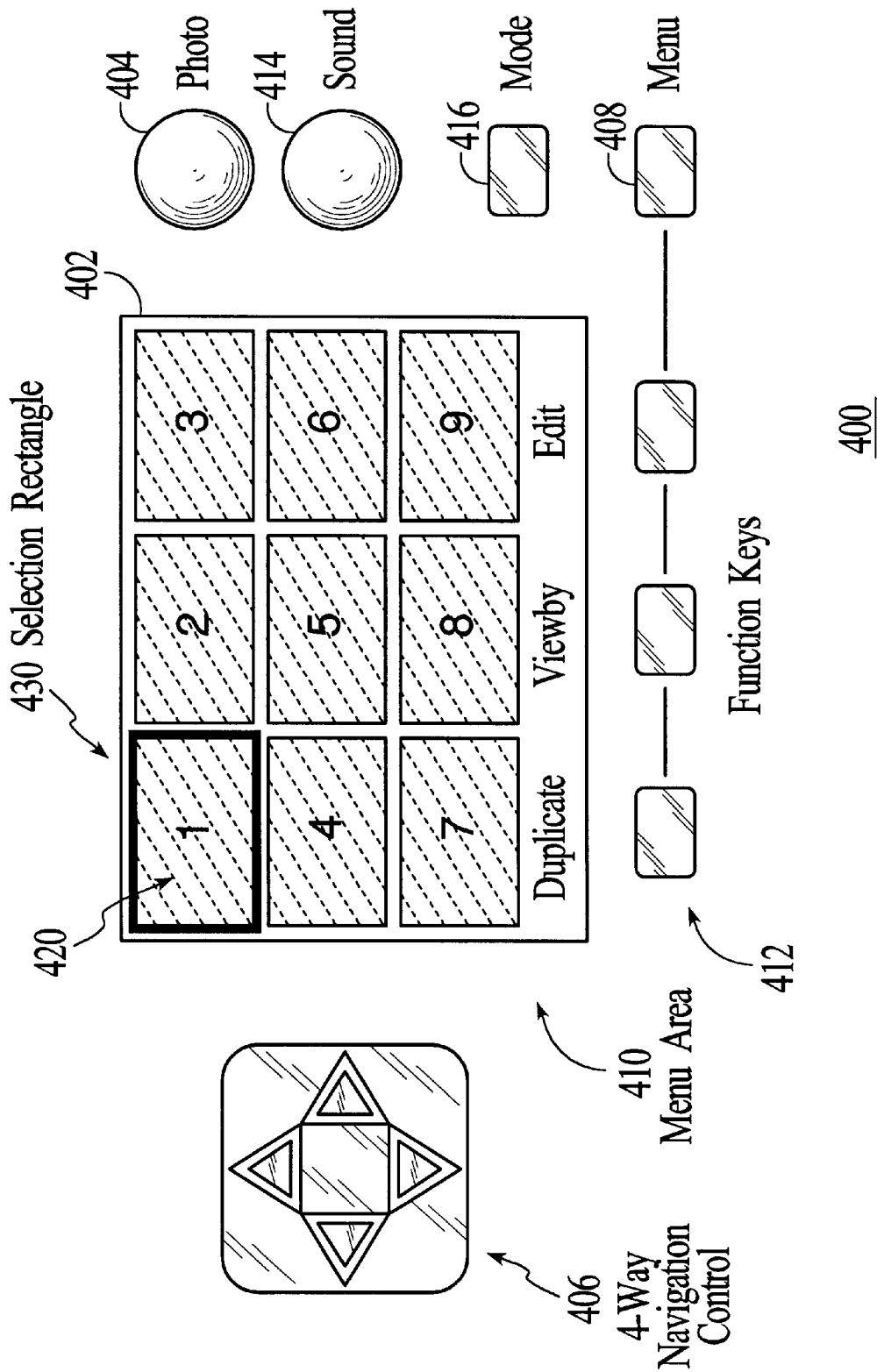

FIG. 6

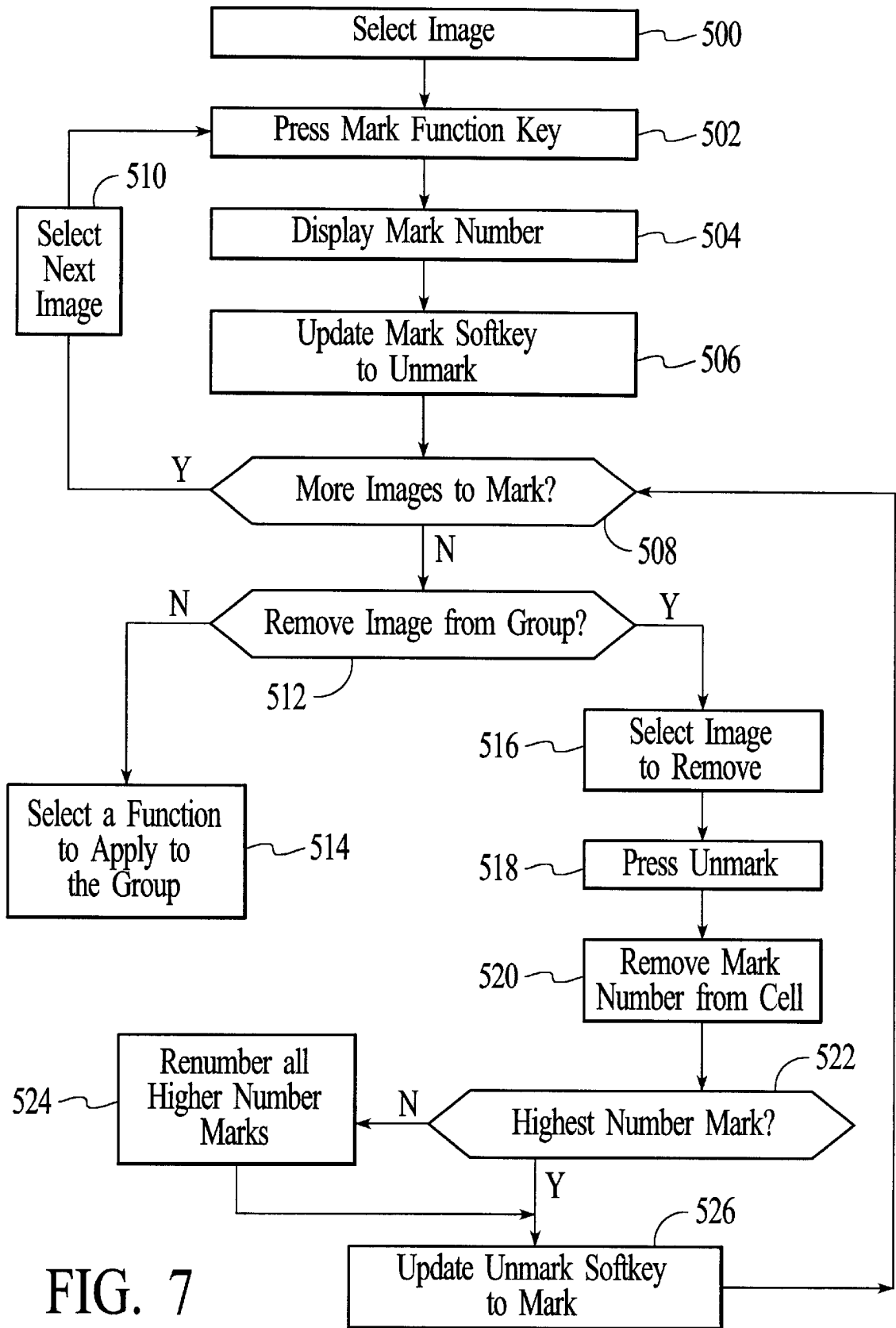

FIG. 7

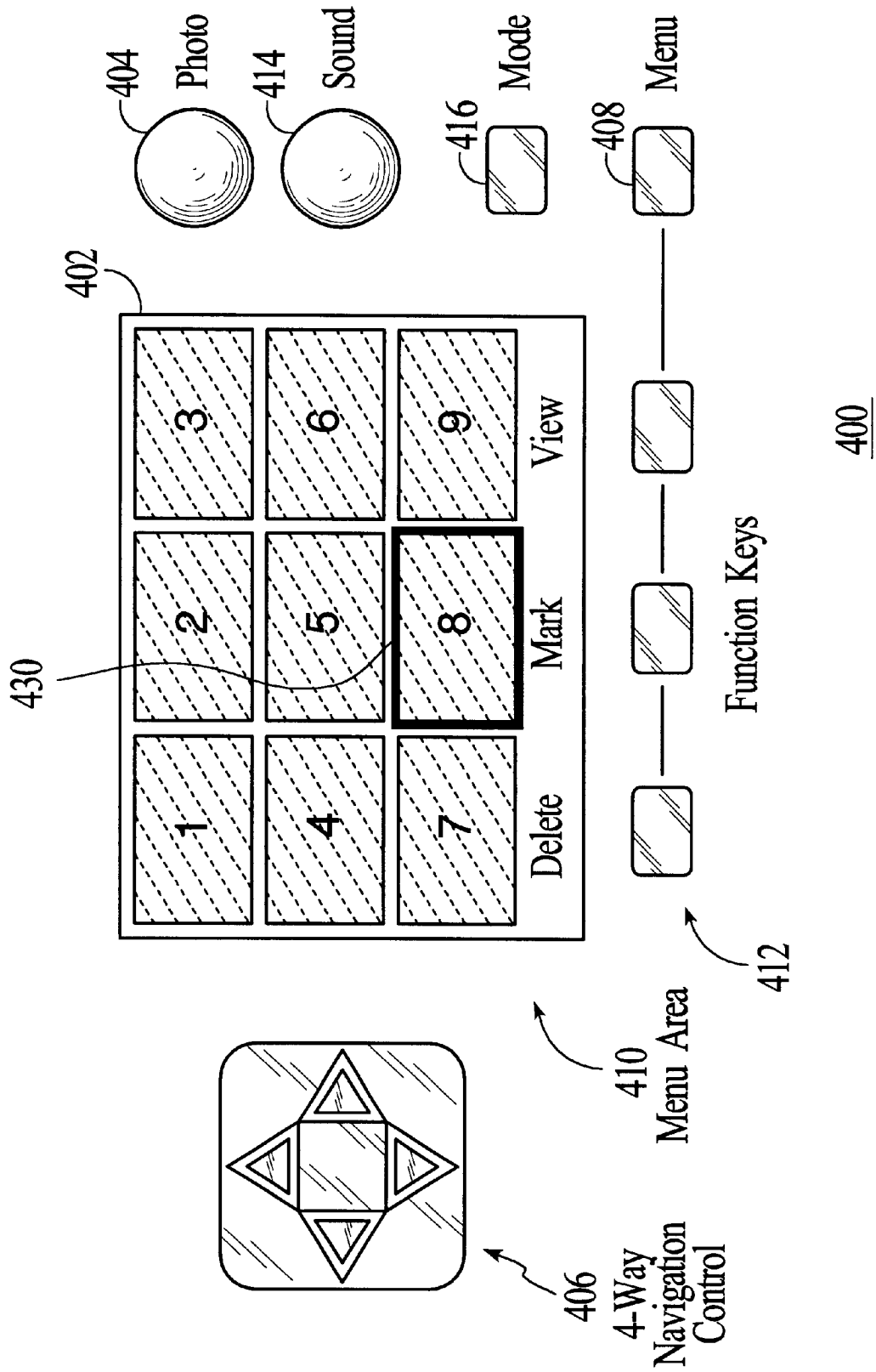

FIG. 8

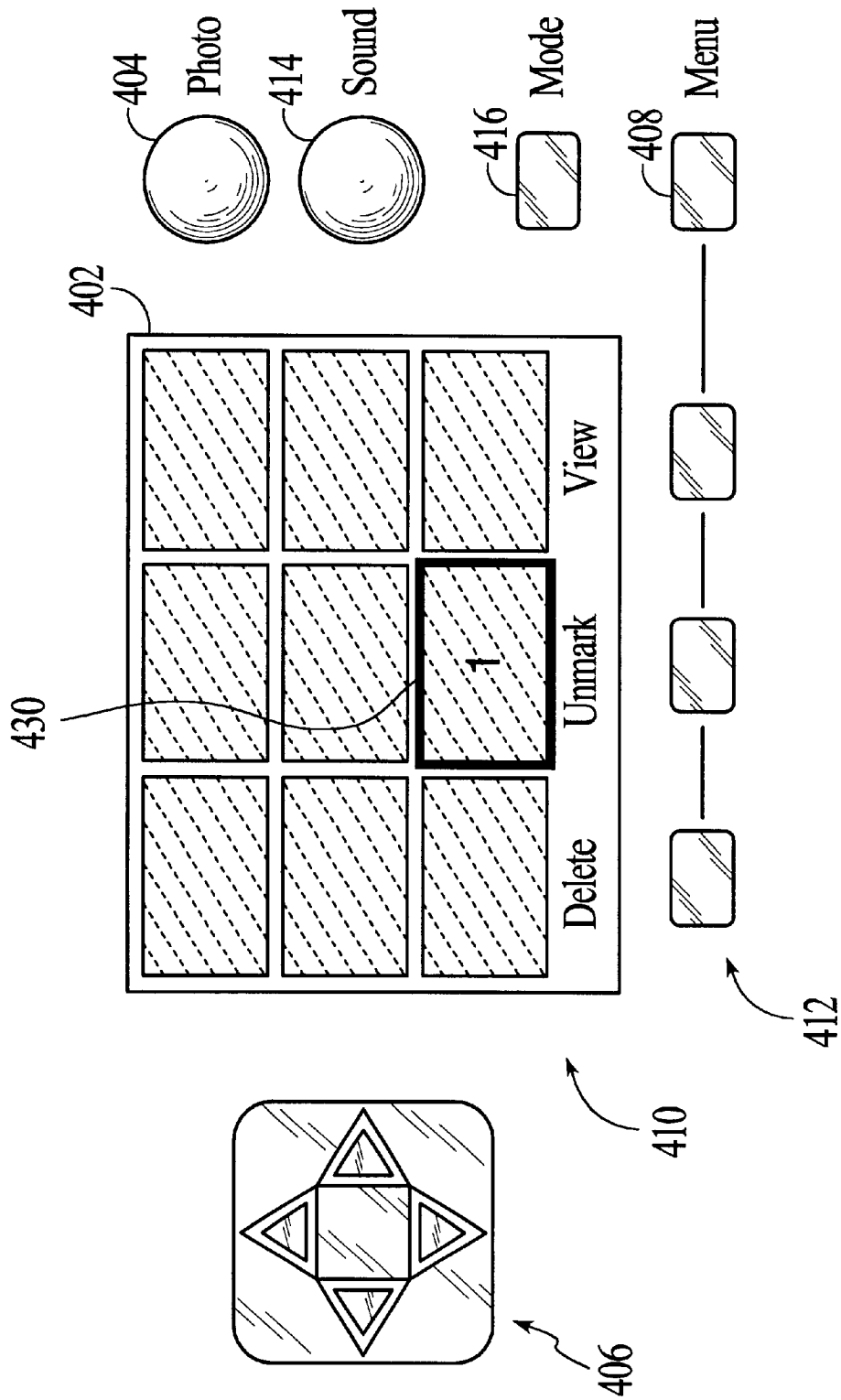

FIG. 9

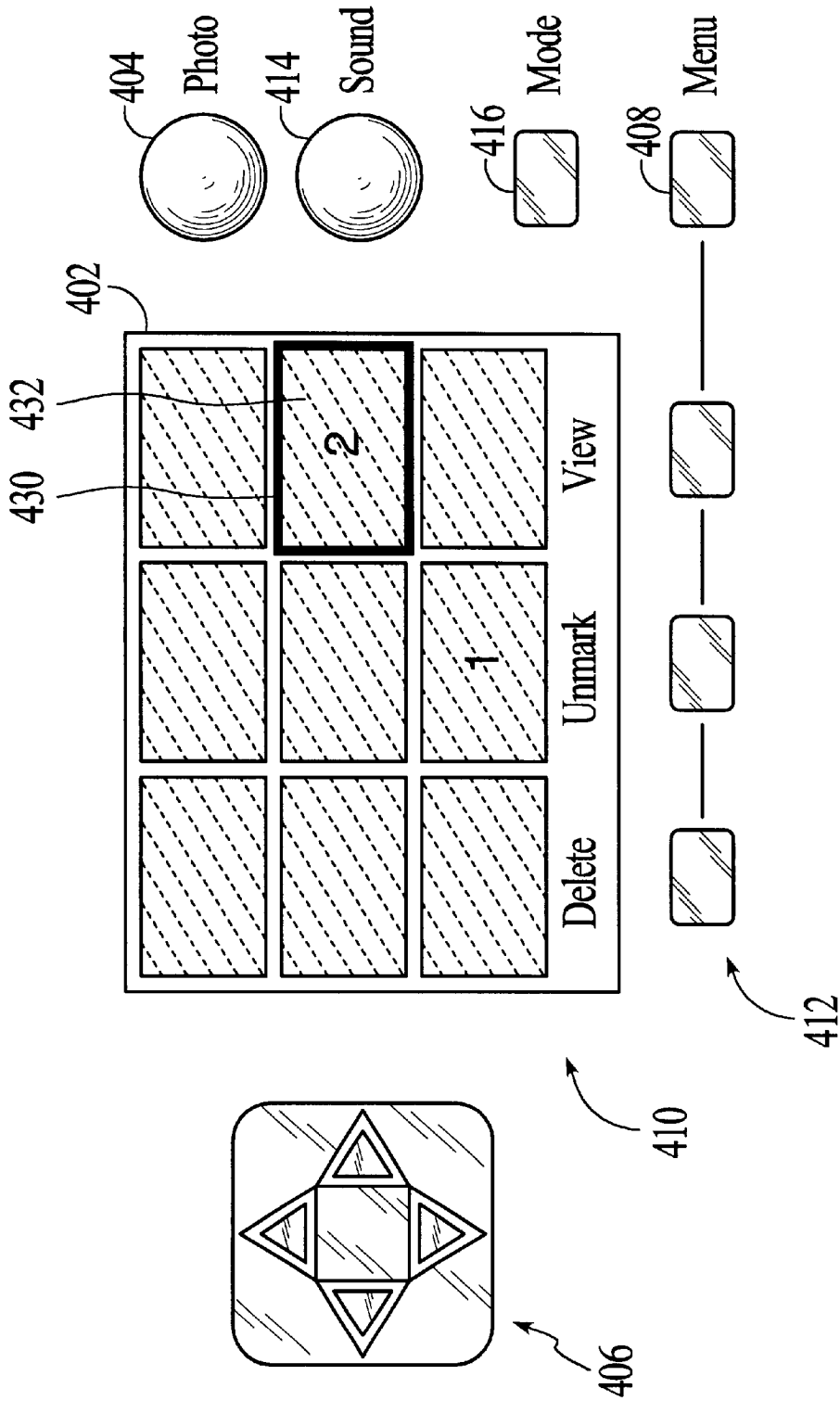

FIG. 10

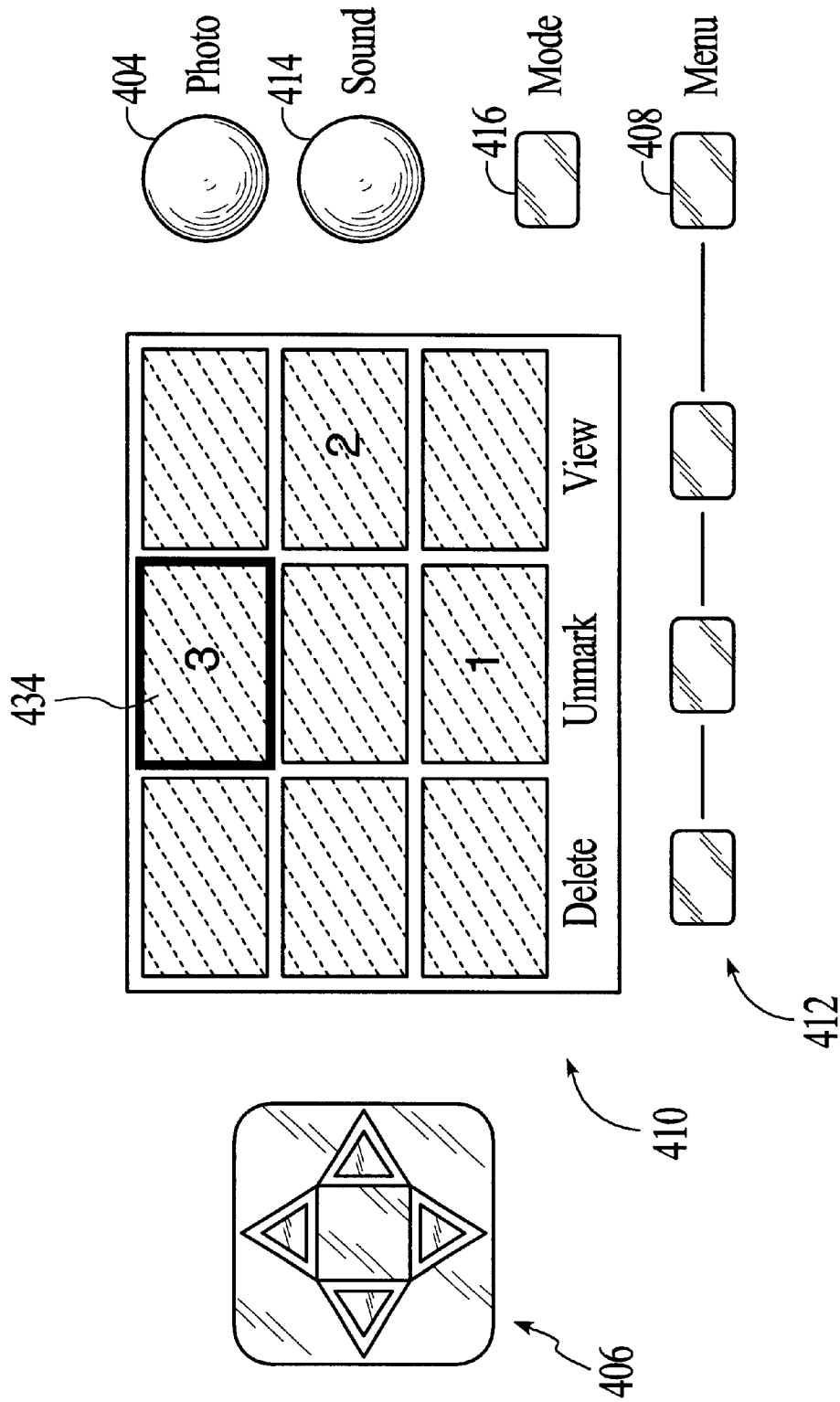

FIG. 11

METHOD AND SYSTEM FOR CREATING A TEMPORARY GROUP OF IMAGES ON A DIGITAL CAMERA

FIELD OF THE INVENTION

The present invention relates generally to digital cameras, and more particularly to a method and system for grouping images in a digital camera.

BACKGROUND OF THE INVENTION

Modern digital cameras typically include an imaging device which is controlled by a computer system. The computer system accesses raw image data captured by the imaging device and then processes and compresses the data before storing the compressed data into an internal memory. Efficient operation of the computer is therefore an important consideration for camera designers and manufacturers. The memory architecture of a particular computer system determines data storage techniques and can thus significantly effect the operational efficiency of the entire digital camera system.

Due to architectural limitations of conventional digital cameras, there are several drawbacks in the user interface that restrict how captured images are manipulated by a user. The user interface in conventional digital cameras typically includes a view finder in which small versions of the captured images may be displayed to allow a user to review several images at once. By selecting one of the images, the user may then display the full-sized version of the images in the view finder.

Some digital cameras have a type of automatic mode that displays the full-sized versions of the captured images at some factory predetermined rate starting with the first image and ending with the last image. Another type of automatic mode allows the user to select the starting image in the playback sequence, rather than automatically starting with the first image that was captured.

The drawback with these types of automatic modes is that once playback begins, the images can only be displayed in the sequence in which they were taken. Therefore, the user cannot fully control the sequence that individual images are displayed, or randomly select a set of images to display.

Digital cameras that are not equipped with automatic mode require manual intervention by the user to display the captured images. That is, not only is the user forced to view images in a predetermined sequence, but after one image is displayed, the user must manually depress a button on the camera that triggers the display of the next image, depress the button again to display the next image, and so on for the entire sequence of images.

Manual intervention by the user is also necessary when performing other operations on the captured images, such as deleting images from the digital camera. Forcing users to manually select individual images for each operation desired can be cumbersome and tedious to the user.

Accordingly, what is needed is an improved system and method for manipulating and grouping captured images in a digital camera. The present invention addresses such a need.

SUMMARY OF THE INVENTION

The present invention provides method and system for grouping a series of images stored in a digital camera. The digital camera includes a view finder for displaying a plurality of the image cells, where each of the image cells corresponds to one of the stored images. The digital camera

also includes a navigation control button for positioning a highlight area around one of the plurality of image cells, and one or more function keys. The method and system includes assigning a mark function to one of the function keys, such that in response to the user pressing the assigned mark function key, the image cell currently highlighted is marked to provide a marked image. In response to the user repeating the above step, a group of marked images is created. The method and system further includes assigning at least one group function to one of the function keys, such that in response to a user pressing the assigned group function key, the temporary group of marked images is collectively manipulated by the user.

Accordingly, to the system and method disclosed herein, a user may view and manipulate randomly selected images as a group without manual intervention, thereby increasing the ease of use and operation of the digital camera.

BRIEF DESCRIPTION OF THE DRAWINGS

FIG. 1 is a block diagram of a digital camera that operates in accordance with the present invention.

FIG. 2 is a block diagram of the preferred embodiment for the imaging device of FIG. 1.

FIG. 3 is a block diagram of the preferred embodiment for the computer of FIG. 1.

FIG. 4 is a diagram depicting a user interface for a digital camera that operates in accordance with the present invention.

FIGS. 5 and 6 are diagrams illustrating additional softkey menu levels that are displayed in the view finder of the camera interface.

FIG. 7 is flow chart depicting the process for grouping images that are stored in a digital camera in accordance with the present invention.

FIGS. 8-11 are diagrams illustrating the user interface as the user groups images in the digital camera in accordance with the present invention.

DESCRIPTION OF THE INVENTION

The present invention relates to an improvement in manipulating images in a digital camera. The following description is presented to enable one of ordinary skill in the art to make and use the invention and is provided in the context of a patent application and its requirements. Various modifications to the preferred embodiment will be readily apparent to those skilled in the art and the generic principles herein may be applied to other embodiments. Thus, the present invention is not intended to be limited to the embodiment shown but is to be accorded the widest scope consistent with the principles and features described herein.

The present invention is a digital camera that includes a method and system for grouping a series of stored images. From the group of images, a user may then automatically display the images in the group, save the images in the group, or delete all of the images in the group at once, without manual intervention.

Referring now to FIG. 1, a block diagram of a camera 110 is shown according to the present invention. Camera 110 preferably comprises an imaging device 114, a system bus 116 and a computer 118. Imaging device 114 is optically coupled to an object 112 and electrically coupled via system bus 116 to computer 118. Once a photographer has focused imaging device 114 on object 112 and, using a capture button or some other means, instructed camera 110 to capture an image of object 112, computer 118 commands

imaging device 114 via system bus 116 to capture raw image data representing object 112. The captured raw image data is transferred over system bus 116 to computer 118 which performs various image processing functions on the image data before storing it in its internal memory. System bus 116 also passes various status and control signals between imaging device 114 and computer 118.

Referring now to FIG. 2, a block diagram of the preferred embodiment of imaging device 114 is shown. Imaging device 114 preferably comprises a lens 220 having an iris, a filter 222, an image sensor 224, a timing generator 226, an analog signal processor (ASP) 228, an analog-to-digital (A/D) converter 230, an interface 232, and one or more motors 234.

In operation, imaging device 114 captures an image of object 112 via reflected light impacting image sensor 224 along optical path 236. Image sensor 224 responsively generates a set of raw image data representing the captured image 112. The raw image data is then routed through ASP 228, A/D converter 230 and interface 232. Interface 232 has outputs for controlling ASP 228, motors 234 and timing generator 226. From interface 232, the raw image data passes over system bus 116 to computer 118.

Referring now to FIG. 3, a block diagram of the preferred embodiment for computer 118 is shown. System bus 116 provides connection paths between imaging device 114, power manager 342, central processing unit (CPU) 344, dynamic random-access memory (DRAM) 346, input/output interface (I/O) 348, read-only memory (ROM) 350, and buffers/connector 352. Removable memory 354 connects to system bus 116 via buffers/connector 352. Alternately, camera 110 may be implemented without removable memory 354 or buffers/connector 352.

Power manager 342 communicates via line 366 with power supply 356 and coordinates power management operations for camera 110. CPU 344 typically includes a conventional processor device for controlling the operation of camera 110. In the preferred embodiment, CPU 344 is capable of concurrently running multiple software routines to control the various processes of camera 110 within a multi-threading environment. DRAM 346 is a contiguous block of dynamic memory which may be selectively allocated to various storage functions.

I/O 348 is an interface device allowing communications to and from computer 118. For example, I/O 348 permits an external host computer (not shown) to connect to and communicate with computer 118. I/O 348 also permits a camera 110 user to communicate with camera 110 via an external user interface and via an external display panel, referred to as a view finder.

ROM 350 typically comprises a conventional nonvolatile read-only memory which stores a set of computer-readable program instructions to control the operation of camera 110. Removable memory 354 serves as an additional image data storage area and is preferably a non-volatile device, readily removable and replaceable by a camera 110 user via buffers/connector 352. Thus, a user who possesses several removable memories 354 may replace a full removable memory 354 with an empty removable memory 354 to effectively expand the picture-taking capacity of camera 110. In the preferred embodiment of the present invention, removable memory 354 is typically implemented using a flash disk.

Power supply 356 supplies operating power to the various components of camera 110. In the preferred embodiment, power supply 356 provides operating power to a main power bus 362 and also to a secondary power bus 364. The main

power bus 362 provides power to imaging device 114, I/O 348, ROM 350 and removable memory 354. The secondary power bus 364 provides power to power manager 342, CPU 344 and DRAM 346.

Power supply 356 is connected to main batteries 358 and also to backup batteries 360. In the preferred embodiment, a camera 110 user may also connect power supply 356 to an external power source. During normal operation of power supply 356, the main batteries 358 provide operating power to power supply 356 which then provides the operating power to camera 110 via both main power bus 362 and secondary power bus 364.

During a power failure mode in which the main batteries 358 have failed (when their output voltage has fallen below a minimum operational voltage level) the backup batteries 360 provide operating power to power supply 356 which then provides the operating power only to the secondary power bus 364 of camera 110. Selected components of camera 110 (including DRAM 346) are thus protected against a power failure in main batteries 358.

Power supply 356 preferably also includes a flywheel capacitor connected to the power line coming from the main batteries 358. If the main batteries 358 suddenly fail, the flywheel capacitor temporarily maintains the voltage from the main batteries 358 at a sufficient level, so that computer 118 can protect any image data currently being processed by camera 110 before shutdown occurs.

According to the present invention, the flexible architecture of the digital camera provides an improved method for manipulating images in a digital camera. More specifically, the present invention provides a method and system for grouping a series of captured images so that the images may be manipulated collectively without user intervention. In a preferred embodiment, the method and system for grouping a series of images is implemented by providing a marking and unmarking function within the user interface of the camera.

FIG. 4 is a diagram depicting a user interface 400 for a digital camera that operates in accordance with the present invention. In one preferred embodiment, the user interface includes a view finder 402, an image capture button called a photo button 404, a four-way navigation control button 406, a menu button 408, a menu area 410 within the view finder 402, and function keys 412. The user interface may also include an optional sound button 414 and a mode button 416.

The particular layout of the user interface 400, however, is not important to implement the present invention. The user interface 400 is preferably located on back of the digital camera, but the user interface buttons may also be positioned in other locations on the camera. For example, the photo button 404 may be positioned on the top of the camera, instead of the back of the camera, etc.

Referring again to FIGS. 1 and 4, the user interface 400 operates in two modes: view finder mode and review mode. In a preferred embodiment, the photo button 404 is a two position button. The view finder mode begins when a user aims the camera at an object 112 and presses the photo button 404 into the first position. Once this occurs, the view finder 402 displays the image of the object 112 as shown through the camera's imaging device 114. The user may then press the photo button 404 into the second position to capture the image shown in the view finder 402. Review mode begins by pressing any other button on the interface 400.

Referring again to FIG. 4, once in the review mode, the view finder 402 displays a series of cells 420 that represent

the digital images that have been captured in the digital camera. The view finder **402** is shown here as displaying nine image cells **420**. Each cell **420** displays what's called a thumb nail of the digital image, which is a shrunken version of the digital image stored in the camera.

While in review mode, the user may navigate through a series of displayed cells **420** in the view finder **402** using the four-way navigation control **406**. The cell **420** currently selected by the four-way navigation control **406** is encircled with a highlighted area **430**, which in this embodiment is a selection rectangle; other shapes for the highlighted area are also suitable.

In a preferred embodiment, the function keys **412** of the user interface **400** are programmable, i.e., they may be assigned different functions. The function currently assigned to a respective function key **412** is indicated by several soft keys that are displayed in the menu area **410** of the view finder **402**. The soft keys displayed in the menu area **410** may be changed by pressing the menu key, which also changes the functions assigned to the function keys **412**. The soft keys displayed in the menu area **410** are also changed automatically by the digital camera in response to user actions, as described further below.

In a preferred embodiment, there are three levels of softkey functions may be displayed in the menu area **410**. FIGS. 4-6 depict the menu area **410** displaying the three levels of softkey functions that are assigned to corresponding function keys **412**. FIG. 4 shows the menu area **410** displaying the first level of soft keys; "Delete", "Mark", and "View". FIG. 5 shows the menu area **410** displaying the second level of soft keys; "Save", "Make", and "View". FIG. 6 shows the menu area **410** displaying the third level of soft keys; "Duplicate", "Viewby", and "Edit".

Referring again to FIG. 4, the "View" softkey is one of the softkeys displayed in the first menu level. Highlighting a cell **420** and pressing the function key **412** under the "View" soft key will cause the full-sized image to be displayed in the view finder **402**.

According to the present invention, rather than performing operations on a single image at one time, a user can create a temporary group of images using the "Mark" softkey. After creating a group, the user may then perform functions on the group, such as deleting the group, or transforming the temporary group into a permanent group of images.

In a preferred embodiment of the present invention, a temporary group of images is created through the use of the "Mark" softkey. In response to the user pressing the function key **412** under the "Mark" softkey, a mark number is displayed in the image cell **420** of the highlighted image and the highlighted image becomes a marked image. After an image is marked, the Mark softkey in the menu area is replaced an "Unmark" softkey. This allows the user remove an image from the group, which removes the mark number from the image cell of the highlighted image.

The "Delete" softkey is the remaining softkey displayed in the first menu level. The delete function provided by the Delete softkey operates on a single image or on a group of marked images. If no images have been marked, then pressing the function key assigned to the delete function will delete the currently highlighted image. If several images have been marked, then pressing the delete function key **412** will delete the temporary group of marked images, even if the highlight area **430** is currently on a non-marked image. In either case, after pressing the delete function key **412**, a dialog box or other type of prompt preferably appears asking the user to confirm the request to delete.

Referring again to FIG. 5, the "Save" and "Make" softkeys are functions that enable the user to create a permanent group of images from the temporary group of marked images. This may be accomplished in a variety of ways.

In one preferred embodiment, pressing the function key under the Save softkey creates a permanent group of images by saving all of the marked images into a folder or directory within the digital camera's DRAM **346** and/or removable memory **354**. A dialog box or other type of prompt appears asking the user to name the folder. After the user names the folder, the folder is displayed as a new cell **420** in the view finder **402**.

In a second preferred embodiment, pressing the save function key creates a permanent group of images by giving the images a common name so that they may sort together during a sort function. In another preferred embodiment, a permanent group of images is created by placing them physically next to each other.

Pressing the function key **412** under the "Make" softkey creates a permanent group by placing all of the marked images into one file, as opposed to a folder. This creates a "slide show" in which the marked images can be played back in the sequence that they were marked. After the Make function key is depressed, a dialog box or other type of prompt appears asking the user to name the file. After the user names the file, the file is displayed as a new cell **420** in the view finder **402**. Highlighting the new slide show cell and pressing the view function causes each of the images included in the "slide show" to be individually displayed in the view finder **402** without user intervention.

According to the present invention, the Save and Make functions allow a group of marked images to be stored in the camera as a single item that can be viewed or played. This allows images to be categorized, e.g., images of a beach scene could be placed in an outdoor category, a family category, an ocean category, a vacation category, or any combination of the above. Instead of creating a duplicate of the image and storing the image in each category, each category would include a pointer to the stored image.

The "Label" softkey is the remaining softkey displayed in the second menu level. Highlighting a folder cell or slide show cell and pressing the function key associated with the Label softkey enables the user to label a folder or file of images with a category name (e.g. beach scenes).

Referring now to FIG. 6, the "Duplicate" softkey operates on a currently highlighted image. Pressing the duplicate function key causes the highlighted marked image to be duplicated. The "Viewby" softkey operates on all images. Pressing the viewby key allows the user to view cells by some criteria, such as by date and time, for example.

According to the present invention, a user may randomly create an ordered group of images using the four-way navigation control **406**, the menu button **408**, the menu area **410**, and the programmable function keys **412**, as shown in FIG. 7.

FIG. 7 is a flowchart depicting the process of creating an ordered group of images in accordance with the present invention.

The process begins when a user selects an image by positioning the highlight area **430** over the image cell using the four-way navigational control button in step **500**. The user then presses the function key corresponding to the Mark softkey in step **502**. After the mark key is depressed, the cell is updated to display the number of images that have been marked during the current sequence in step **504**. The cell may also be updated to display an optional graphic, such as

a check-mark for example. After the image cell has been updated, the mark softkey in the menu area is updated to "Unmark" in step 506.

Next, the user decides whether to add more images to the temporary set of marked images in step 508. If the user decides to add more images, then the user selects the next image by positioning the highlight area over the image using the four-way navigational control button in step 510.

If the user decides not to add more images to the temporary group of marked images in step 508, then the user decides whether to remove any of the marked images from the group in step 512. If the user decides not to remove any of the marked images from the group, then the user may select a function, such as "Delete", "Save", and "Make", to apply to the group in step 514.

If the user decides to remove a marked image from the group, then the group is dynamically modified as follows. The user first selects the image to be removed by positioning the highlight area over the marked image using the fourway navigational control button in step 516. The user then presses the function key corresponding to the Unmark softkey in step 518.

After the unmark key is depressed, the cells for the remaining marked images may be renumbered. This is accomplished by determining whether the selected image is the highest numbered image in the marked group in step 522. If the selected image is not the highest numbered image in the marked group, then the marked images having a higher number are renumbered by subtracting one from the respective mark number and displaying the result in their cells in step 524. After the mark number is removed from the unmarked image and the other mark numbers renumbered if required, the unmark softkey in the menu area is updated to "Mark" in step 526. The user may then continue to modify the group by marking and/or unmarking other images accordingly.

The process of grouping images in the digital camera will now be explained by way of a specific example with reference to FIGS. 8-11.

Referring to FIG. 8, assume that the user wishes to create a group of images beginning with the image cell highlighted with the highlighted area 430. At this point, the soft keys displayed in the menu area 410 are prompts to the user that the user may perform the displayed functions, such as "Mark", on the highlighted image. The mark function is then performed by the user pressing the Mark function key that is associated with the "Mark" soft key.

FIG. 9 is a diagram showing the result of the user pressing the Mark function key. The highlighted image cell 430 is updated with the number "1", which indicates that the image is the first to be marked. After marking the image, the menu area 410 is automatically updated with the "UnMark" soft key. Pressing the corresponding UnMark function key would result in the number "1" being removed from the image cell.

FIG. 10 is a diagram showing the user marking another image by positioning the highlight area 430 over a second image cell 432 and pressing the Mark function key. This causes the highlight image cell 432 to be updated with the number "2". As a result of marking the image, the menu area 410 is automatically updated with the "UnMark" soft key.

FIG. 11 is a diagram showing a third image being selected and marked, as described above, in which case, the icon area of the image 434 is updated with the number "3".

Referring again to FIG. 7, while marking images, the method for removing images in the group (steps 512-524)

also allows a user to dynamically reorder or re-sequence the images in the group. For example, assume the user has marked five images, labeled as "1", "2", "3", "4", "5", and wants to make image "3" the last image in the group. This can be accomplished by unmarking image "3", which results in images "4", and "5" being renumbered "3" and "4", respectively. Thereafter, the user may mark the original image "3", which results in the image being labeled with the number "5".

After the group has been created with the chosen images in the desired sequence, the user may manipulate the marked images using functions chosen from the menu levels. Using the group functions provided by the programmable softkeys, the user may save the group into a folder, create a slide show, view the group, or delete the group.

A method and system for grouping images in a digital camera has been disclosed that is an improvement in the way images may be manipulated in a digital camera. Although the present invention has been described in accordance with the embodiments shown, one of ordinary skill in the art will readily recognize that there could be variations to the embodiments and those variations would be within the spirit and scope of the present invention.

For example, many methods may be chosen for displaying optional functions that may be performed on the images. For instance, the soft keys shown may be displayed on any menu level according to the application, or the softkeys may be replaced with actual buttons on the camera interface. Also, instead of displaying the soft keys in the menu area 410 itself to indicate whether the selected image will be marked, unmarked or duplicated, a dialog box may be displayed in the view finder 402 that prompts the user whether they want the current image to be marked, unmarked, or duplicated.

Accordingly, many modifications may be made by one of ordinary skill in the art without departing from the spirit and scope of the appended claims.

What is claimed is:

1. A method for grouping a series of images stored in a digital camera, the digital camera including a view finder for displaying the stored images, a navigation control button, and one or more function keys, the method comprising the steps of:

- (a) allowing a user to navigate among the displayed images using the navigation control button;
- (b) allowing the user to randomly select one of the displayed images;
- (c) assigning a mark function to one of the function keys, such that in response to a user pressing the assigned mark function key, the image currently selected is marked to provide a marked image;
- (d) repeating steps (a) through (c) to create a temporary group of marked images; and
- (e) assigning at least one group function to one of the function keys, such that in response to the user pressing the assigned group function key, the group of marked images is collectively manipulated by the user within the digital camera.

2. A method as in claim 1 wherein step (e) further includes the step of:

- (e1) providing a view function as the at least one group function, such that in response to a user pressing the assigned view function key, each of the marked images is displayed sequentially in the view finder without manual intervention.

3. A method as in claim 1 wherein step (e) further includes the step of:

(e1) providing a save function as the at least one group function, such that in response to a user pressing the assigned save function key, a permanent group of images is created by saving each of the marked images in a folder.

4. A method as in claim 1 wherein step (e) further includes the step of:

(e1) providing a slide show function as the at least one group function, such that in response to a user pressing the assigned slide show function key, a permanent group of images is created by saving each of the marked images in a file.

5. A method as in claim 1 wherein step (e) further includes the step of:

(e1) providing a duplicate function as the at least one group function, such that in response to a user pressing the assigned duplicate function key, each of the marked images are duplicated, and if no images have been marked, then the image currently selected is duplicated.

6. A method as in claim 1 wherein step (e) further includes the step of:

(e1) providing a delete function as the at least one group function, such that in response to a user pressing the assigned delete function key, each of the marked images is deleted, and if no images have been marked, then the image currently selected is deleted.

7. A method as in claim 1 further including the step of:

(f) assigning an unmark function to one of the function keys, such that in response to the user pressing the assigned unmark function key, the mark number is removed from the image currently selected is unmarked.

8. A method for grouping a series of images stored in a digital camera, the digital camera including a navigation control button, one or more function keys, and a view finder for displaying stored images, the method comprising the steps of:

- (a) allowing a user to navigate among the displayed images using the navigation control button;
- (b) allowing the user to randomly select one of the displayed images;
- (c) enabling the user to mark the selected image using a corresponding function key;
- (d) displaying a mark indication on the selected image in response to the user pressing the corresponding function key;
- (e) repeating steps (a) through (d) to provide a temporary group of marked images;

(f) enabling the user to select one of the functions of saving the group, deleting the group, and creating a slide show from the group using a corresponding function key; and

(g) saving the group, deleting the group, and creating a slide show from the group in response to the user pressing the appropriate function key.

9. A method as in claim 8 wherein step (d) further includes the step of:

(d1) providing a mark number as the mark indication.

10. A method as in claim 9 further including the steps of:

(h) allowing the user to unmark the selected image using a corresponding function key; and

(i) removing the mark indication from the selected image in response to the user pressing the corresponding function key.

11. A method as in claim 10 wherein step (a) further includes the step of:

(b1) prompting the user to duplicate the selected image using a corresponding function key; and

(b2) duplicating the selected image in response to the user pressing the corresponding function key.

12. A digital camera device comprising:

- a memory device for storing sets of image data;
- a memory manager for allocating storage locations within said memory device to store said sets of image data;
- an interface coupled to said memory device whereby an external host computer can access said sets of image data stored in said memory device;
- a user interface for displaying a plurality of images corresponding to the image data, the user interface including a plurality of function keys, and means to navigate among and randomly select one of the plurality of images;

means coupled to the memory manager for assigning a mark function to one of the function keys, such that in response to the user pressing the assigned mark function key, the selected image is marked, such that in response to the user repeatedly selecting images and pressing the assigned mark function key, a temporary group of marked images is created; and

means coupled to the memory manager for assigning at least one group function to one of the function keys, such that in response to a user pressing the assigned group function key, the group of marked images is collectively manipulated by the user, within the digital camera.

* * * * *